

---

**RANGE SUMMARY**

---

The SuperSafe™ T Front Terminal range of valve regulated lead acid batteries has been designed specifically for use in applications which demand the highest levels of security and reliability. With proven compliance to the most rigorous international standards, SuperSafe T is recognised worldwide as a premium battery for Telecom applications. SuperSafe T's reputation for long service life, together with excellent high rate performance, also makes it ideal for high integrity, high specification UPS systems.

SuperSafe T delivers superior performance while occupying less space than conventional standby power batteries. The SuperSafe T Front Terminal monobloc's compact design, suitable for 19", 23" and ETSI racking, provides users with the benefit of increased energy density. With all electrical connections at the front, installation and inspection are both quicker and easier.

SuperSafe T batteries are designed using proven gas recombination technology which removes the need for regular water addition by controlling the evolution of hydrogen and oxygen during charging. Oxygen evolved at the positive plates diffuses through microporous separators to the negative plates, and, by a series of chemical reactions within the cell, recombines to form water. Each cell incorporates its own safety valve that allows the controlled release of gas when pressure builds up within the cell.

The use of gas recombination technology for lead acid batteries has totally changed the concept of standby power. This technology provides the user with the freedom to use lead acid batteries in a wide range of applications.

### Features & Benefits

- Capacity range: 31Ah - 170Ah
- Front terminal connections for fast and easy installation and maintenance
- Suitable for 19", 23" and ETSI racking
- UL94 V-0 flame retardant case and lid
- High reliability
- Proven long service life



## Construction

- Positive plates designed to prolong service life and enhance corrosion resistance
- Separators in low resistance microporous glass fibre. The electrolyte is absorbed within this material, preventing acid spills in case of accidental damage
- Case and lid in flame retardant ABS material, highly resistant to shocks and vibrations
- Terminal with brass insert for maximum conductivity and with high compression grommet for long life
- Self-regulating pressure relief valve prevents ingress of atmospheric oxygen

## Installation & Operation

- The SuperSafe T Front Terminal range is designed for installation in cabinets or on stands, close to the point of use. A separate battery room is not necessary
- It is recommended that SuperSafe T Front Terminal monoblocs are installed on their base
- Recommended float charge voltage: 2.280Vpc at 20°C (68°F) 2.265Vpc at 25°C (77°F)
- Six months shelf life at 20°C
- Reduced maintenance: no water addition required

## Standards

- In compliance with the requirements of the international IEC 60896-21/22 standard
- Classified as "Long Life" according to the Eurobat Guide 1999
- Designed to meet Telcordia SR-4228 requirements
- Recognised by UL (UL Standard 1989)
- Approved to be shipped as non-hazardous cargo in accordance with the requirements of IMDG (International Maritime code for Dangerous Goods) and OICA (Organisation of International Civil Aviation)
- Manufactured in EnerSys production facilities certified to ISO 9001:2000

## General Specifications

Type	Number of Cells	Nominal Voltage (V)	Nominal Capacity (Ah)		Nominal Dimensions				Overall Height		Typical Weight		Short Circuit Current (A)	Internal Resistance (mΩ)	Terminals
			10 hr rate to 1.80Vpc @ 20°C	8 hr rate to 1.75Vpc @ 77°F	Length mm	Length in	Width mm	Width in	mm	in	kg	lbs			
12T30F	6	12	31	31	280	11.0	97	3.8	159	6.3	10.8	23.8	1327	9.87	M8 F
12T38F	6	12	38	38	280	11.0	97	3.8	184	7.2	12.5	27.6	1500	8.53	M8 F
12T62F	6	12	62	62	280	11.0	97	3.8	264	10.4	19.7	43.5	2100	5.87	M8 F
12T92F*	6	12	92	92	395	15.6	105	4.1	264	10.4	28.0	61.7	2500	5.05	M8 F
12T105F*	6	12	105	107	561	22.1	125	4.9	235	9.3	46.0	101.4	3500	3.60	M6 M
12T125F*	6	12	125	126	561	22.1	105	4.1	316	12.4	56.0	123.5	3818	3.30	M6 M
12T155FS*	6	12	150	155	561	22.1	125	4.9	283	11.1	57.0	125.6	3435	3.20	M6 M
12T170F*	6	12	170	170	561	22.1	125	4.9	316	12.4	67.0	147.7	3667	3.40	M6 M

\* With rope handles

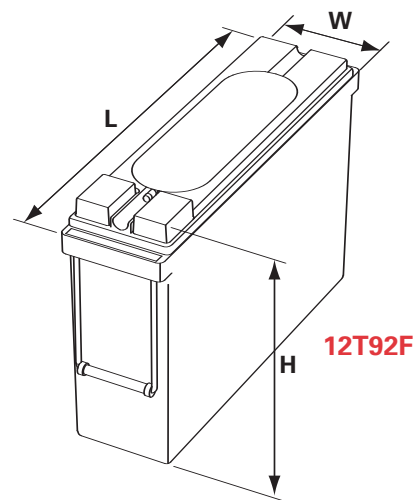
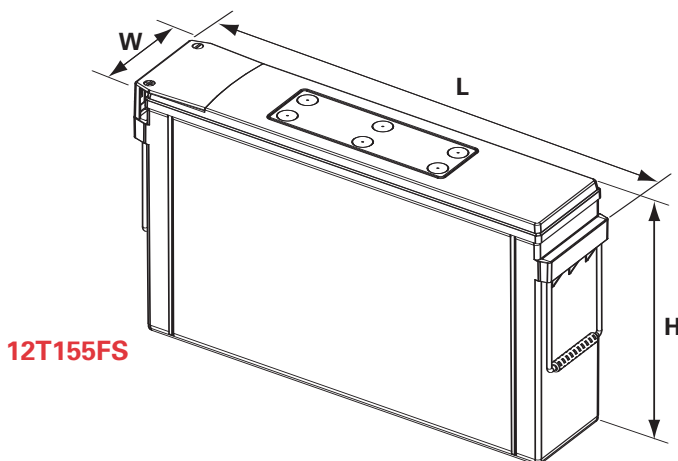

**EnerSys**  
 P.O. Box 14145  
 Reading, PA 19612-4145  
 USA  
 Tel: +1-610-208-1991  
 +1-800-538-3627  
 Fax: +1-610-372-8613

**EnerSys EMEA**  
 Houtweg 26  
 1140 Brussels  
 Belgium  
 Tel: +32 (0)2 247 94 47  
 Fax: +32 (0)2 247 94 49

**EnerSys Asia**  
 49, Yanshan Road  
 Shekou, Shenzhen  
 Guangdong 518066  
 China  
 Tel: +86-755-2689 3639  
 Fax: +86-755-2689 8013

Contact:

© 2006 EnerSys. All rights reserved.  
 Trademarks and logos are the property of EnerSys and its affiliates unless otherwise noted.